

## Applies To

All Models with Ball / Socket Xbar Center Junctions – Falcons, XCs, Ultra Sports, Eagles, Condors, U2s, Sport 2s

## Introduction

In 1994, beginning with the Falcon 195 model, we began using a UHMW machined ball and socket joint, in combination with a hinge bracket assembly on the crossbar center section of all glider models (except “topless” models).



Originally, the center hinge fastener in this assembly was an NAS 623 517 Bolt and 5/16 Clinch Nut. In the spring of 2002, we switched to a combination of a 4C-37 Clevis Pin, a 5/16" Pushnut, and a safety ring for the center hinge pin in this assembly (pictured above, on left). In late 2004, we switched this assembly again to a grooved 5/16" clevis pin and a snap ring retainer (pictured above, on right.)

We switched to the snap ring and grooved pin originally because after using the push nut and safety ring assembly successfully for more than two years, we began to see cases where the push nut was not adequately or securely engaging the clevis pin. Since switching to the snap ring, we have found that the snap ring can be dislodged from the pin in apparently normal use, allowing the pin to fall out and disconnecting the hinge brackets (and thereby the crossbar halves) from one another. Although this pin connection is not a load bearing assembly in flight, it does serve to guide the ball on one crossbar into proper engagement with the socket on the other crossbar during set-up, and maintain that alignment at any time that the crossbars are not loaded. We have changed our assembly procedures to again incorporate a bolt and locknut in this assembly, and we are recommending that all gliders manufactured with the grooved pin and snap ring assembly, or with the push nut and safety ring assembly, be upgraded to the bolt and nut assembly. We have also replaced the nylon washers between the hinge brackets on the hinge bolt with brass washers, and recommend that these washers be replaced when the pin is replaced by the bolt and nut.

## Parts Required

<u>ID</u>	<u>DESCRIPTION</u>	<u>QTY</u>
10C-5182	BOLT NAS 623-418 (NO HOLE)	1
10N-0040	LOCKNUT LOW PRO 52NKTE-048	1
10U-4100	WASHER BRASS .625X .281X .04	4

## Tools Required

- 7/16" wrench
- Phillips screwdriver (med to large point)
- Flat blade screwdriver (med to small)
- Needle nose pliers

## Procedures – Inspection, Replacement, Adjustment

Set up the glider on the control bar, and spread the wings most of the way. Do not tension the cross-bar or install the battens. On a glider equipped with the clevis pin, push nut and safety ring, use the needle nose pliers to remove the safety ring, and use the flat blade screwdriver to pry the push nut off of the clevis pin. Remove the clevis pin. On a glider equipped with the snap ring and grooved clevis pin, use the flat blade screwdriver to spread the ends of the snap ring, and then use the needle nose pliers to push the snap ring off of the grooved pin. Remove the pin.

Re-assemble the center hinge assembly following the assembly diagram below, installing the appropriate washers in the indicated locations. Be SURE to assemble the hinge brackets with the right side bracket above the left side bracket as shown.

DO NOT OVERTIGHTEN THE NUT. Install the nut finger tight, and then tighten it four full turns. This should leave it one-third turn from fully tight, and should allow the bolt to turn freely within the brackets with little resistance, while still affording four full turns of locking engagement on the nut

Note: Right-side bracket must be assembled on top of left-side bracket as shown below

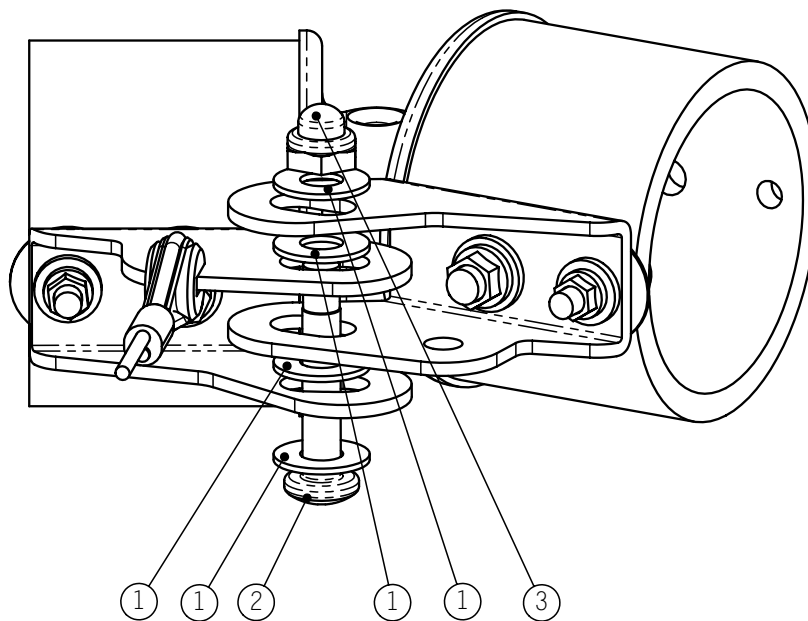

ITEM	Part No	Description	QTY
1	10U-4100	WASHER BRASS .625X .281X .04	4
2	10C-5181	NAS623-4-18	1
3	10N-0040	LOCKNUT LOW PRO 52NKTE-048	1